



Three setpoints allow control of complex operations... built-in batch counter can run a set number of cycles

The SX110 is a microprocessor based control that combines a three setpoint repeat cycle timer with an internal batch counter. The three setpoints on the repeat cycle timer function allow overlap or dwell between the two output timing intervals. The batch counter counts the number of repeat cycle operations that the timer performs and automatically stops the timer operation after the user programmed number of cycles.

The repeat cycle timer can operate as either a DPDT relay output with ON and OFF times or as two independent SPDT relay interval outputs. When operated as two interval outputs, a third setpoint is available that can provide overlap of the two intervals or a dwell period between the two intervals. The time ranges for the output sequences are individually programmable. There are four time ranges available for each output sequence from 99.99 seconds to 99 hours: 59 minutes.

The internal batch counter counts the number of cycles of the repeat timer output. The batch counter will also automatically stop the timing operation after the programmed number of cycles. The batch counter can be set to allow from 1 to 9999 cycles, or it can be set to provide continuous repeat cycle operation.

The SX110 is housed in a standard DIN case (68mm square cutout). The case and front bezel require minimal panel space yet provide easy to use programming keys and an easy to read .36 inch LED display.

The operating modes and time ranges for the unit are programmed using rocker switches on the back of the unit. This programming method provides both simplicity and security. The front panel display has a prompted programming routine that prompts the user when to program the ON and OFF times as well as the batch counter setpoint.

Some of the other features of the SX110 timer include:

- NEMA 4 Hosedown Test rated
- Two 5 amp SPDT relay outputs
- Four output operating modes
- Four independently programmable time ranges for the ON and OFF times
- Time inhibit input
- LED indicators for output status
- Setpoint to zero or zero to setpoint cycle progress indication

SPECIFICATIONS

Time Ranges:

Sym.	Maximum Range	Minimum Setting
1	99.99 Sec.	.01 Sec.
2	999.9 Sec.	.1 Sec.
3	99 Min.: 59 Sec.	1 Sec.
4	99 Hr.: 59 Min.	1 Min.

Operating Voltage/Frequency: A6 - 120 VAC, 50/60 Hz

Batch Counter Range: 1-9999 or continuous

Setting Accuracy: Time: $\pm 0.05\%$ of setting or 50 ms, whichever is larger
Count: 100%

Repeat Accuracy: Time: $\pm 0.001\%$ of setting or 35 ms, whichever is larger
Count: 100%

Reset Time: 15 ms

Power on Response: 200 ms max.

Operating Temperature: +32° to +122°F (0° to +50°C)

Sensor Power Supply: +12 VDC, 75 milliamps

Output Rating: Relay: 5 amp (resistive), 10 to 264 VAC

Vibration: Unit function is unaffected by 2.5G sinusoidal vibration magnitude in both directions of the perpendicular mounting axes imposed from 10 to 100 Hz

Static Discharge: Unit function is unaffected by a constant 3600 volt peak, 60 Hz discharge applied to the grounded front plate at a relative humidity of less than 25%

Transient Protection: Immune to 2500 volts peak transients up to 50 microseconds in duration

OUTPUT OPERATING MODES

DPDT - OFF Time First

Both outputs are energized together. The OFF time defined by Setpoint 1 (SEt1) occurs first.

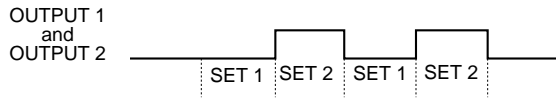

DPDT - ON Time First

Both outputs are energized together. The ON time defined by Setpoint 1 (SEt1) occurs first.

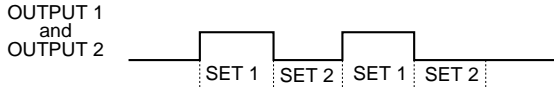

Overlapping Intervals

Output 1 is ON first. Output 2 is normally energized at the end of the Output 1 timing interval. The Output 2 timing interval can be programmed to begin before the end of the Output 1 interval by using Setpoint 3 (SEt3). Setpoint 3 is the amount of time before the end of the Output 1 interval that the Output 2 interval is started. In repeat operation, Output 1 is energized again at the end of the Output 2 interval.

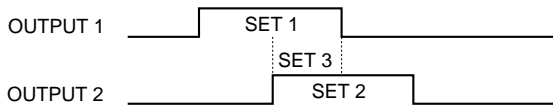

Non-Overlapping Intervals

Output 1 is ON first. Output 2 is normally energized at the end of the Output 1 timing interval. The Output 2 timing interval can be programmed to begin a delay or dwell period after the end of the Output 1 interval by using Setpoint 3 (SEt3). Setpoint 3 is the amount of time after the end of the Output 1 interval that the Output 2 interval is started. In repeat operation, the Setpoint 3 dwell period also occurs after the Output 2 interval and before the Output 1 interval repeats.

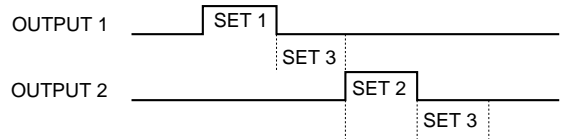

TERMINAL ASSIGNMENTS

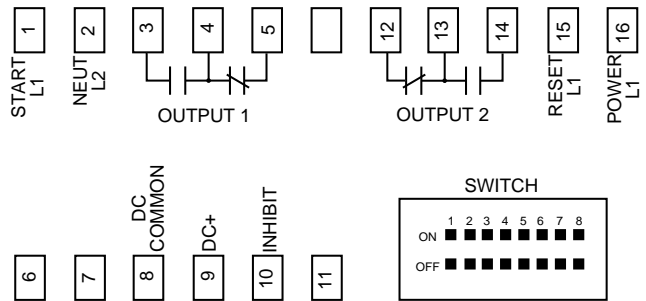

Terminals 6, 7, and 11 are not used on the SX110 timer.

MOUNTING

The SX110 timer uses two removable mounting clips with adjustable screws to mount the enclosure in a panel as shown below.

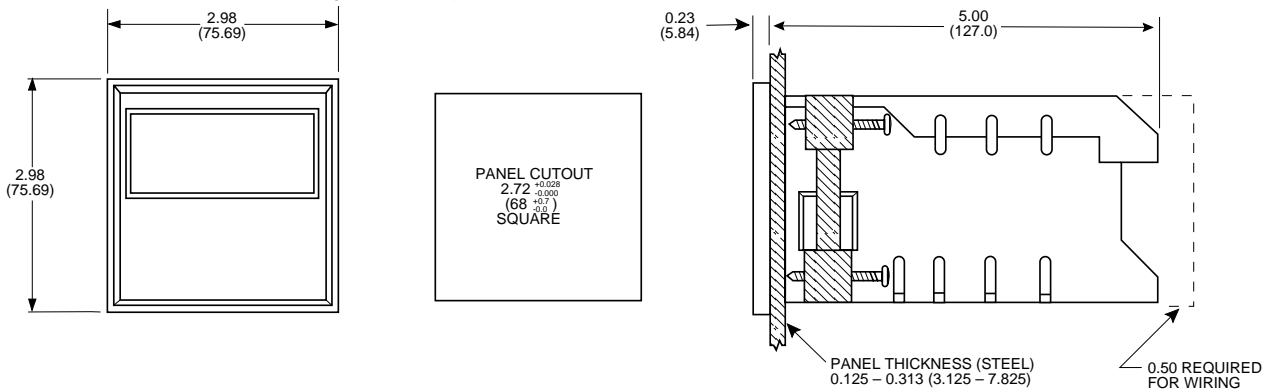

ORDERING INFORMATION

OUTPUT TYPE		SX1	10	A6	VOLTAGE & FREQUENCY	
Sym.	Description				Sym.	Description
10	Relay Output				A6	120 VAC, 50/60 Hz