

HART Protocol Cylindrical Temperature Transmitters



CN-502H Series PRODUCT MANUAL

For your safety, read and follow the considerations written in the instruction manual, other manuals and Autonics website.

The specifications, dimensions, etc. are subject to change without notice for product improvement. Some models may be discontinued without notice.

Features

- HART protocol
- Multi-input
 - RTD 8 types
 - Thermocouple 7 types
 - mV 4 types
 - Resistor 2 types
- Small size: $\varnothing 44 \times 24$ H
- High accuracy: $\pm 0.3\%$ F.S.

Safety Considerations

- Observe all 'Safety Considerations' for safe and proper operation to avoid hazards.
- \triangle symbol indicates caution due to special circumstances in which hazards may occur.

\triangle Warning Failure to follow instructions may result in serious injury or death.

- 01. Fail-safe device must be installed when using the unit with machinery that may cause serious injury or substantial economic loss. (e.g. nuclear power control, medical equipment, ships, vehicles, railways, aircraft, combustion apparatus, safety equipment, crime/disaster prevention devices, etc.)**
Failure to follow this instruction may result in personal injury, economic loss or fire.
- 02. Do not use the unit in the place where flammable/explosive gas, high humidity, direct sunlight, radiant heat, vibration, impact, or salinity may be present.**
Failure to follow this instruction may result in explosion or fire.
- 03. Do not connect, repair, or inspect the unit while connected to a power source.**
Failure to follow this instruction may result in electric shock.
- 04. Do not disassemble or modify the unit.**
Failure to follow this instruction may result in fire or electric shock.
- 05. Check 'Connections' before wiring.**
Failure to follow this instruction may result in fire.

\triangle Caution Failure to follow instructions may result in injury or product damage.

- 01. Use the unit within the rated specifications.**
Failure to follow this instruction may result in fire or product damage.
- 02. Use a dry cloth to clean the unit, and do not use water or organic solvent.**
Failure to follow this instruction may result in fire or electric shock.
- 03. Keep the product away from metal chip, dust, and wire residue which flow into the unit.**
Failure to follow this instruction may result in fire or product damage.

Cautions during Use

- Follow instructions in 'Cautions during Use'.
Otherwise, it may cause unexpected accidents.
- 11-35 VDC \equiv model power supply should be insulated and limited voltage/current or Class 2, SELV power supply device.
- Keep away from high voltage lines or power lines to prevent inductive noise
Do not use near the equipment which generates strong magnetic force or high frequency noise.
- Install a power switch or circuit breaker in the easily accessible place for supplying or disconnecting the power.
- In case of connecting RTD temperature sensor, must use 3-wire or 4-wire system in which all wires have same length and thickness. In case of extending wire of thermocouple (TC) temperature sensor, must use designated compensation wires.
- This unit may be used in the following environments.
 - Indoors (in the environment condition rated in 'Specifications')
 - Altitude ax 2,000m
 - Pollution Degree 2
 - Installation Category II

Dimensions

- Unit: mm, For the detailed drawings, follow the Autonics website.

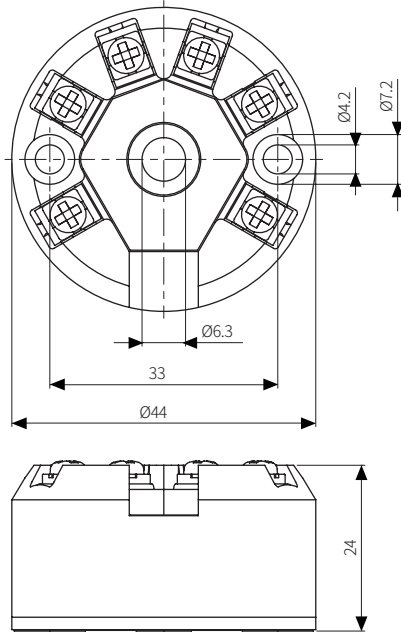

Connections

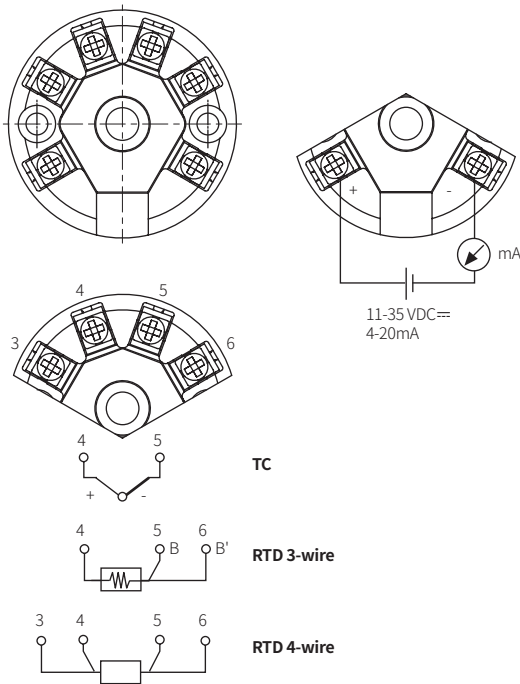

Specifications

Model	CN-502H
Power supply	11-35 VDC≒
Power consumption	≤ 1 W
Display method⁰¹⁾	No mark
Measurable current	50 μA (3-wire), 100 μA (4-wire)
Resistance	≤ 5 Ω
Input specification	Refer to 'Input Specifications'
Input accuracy	± 0.1 % F.S.
Output	DC 4-20 mA (2-wire)
Output accuracy	± 0.1 % F.S.
Response time	1 sec (10 to 90 % of output)
Load	≤ (Power supply-11 VDC≒) / 0.023 A
Setting method	HART-protocol (no setting key)
Alarm	≤ 3.8 mA, > 21.0 mA, sensor break 22 mA or 3.6 mA
Sampling period	500 ms
Unit weight (Packaged)	≈ 26 g (≈ 66 g)

01) Parameter setting and state monitoring are available through an external device such as HART communicator or loader.

Dielectric strength	1000 VAC~ 50/60 Hz 1 min (between all terminals and case)
Noise immunity	IEC 61326-1
Vibration	0.75 mm amplitude a frequency of 5 to 55 Hz in each X, Y, Z direction for 2 hours
Insulation resistance	≥ 100 MΩ (500VDC≒ megger)
Memory protection	≈ 10 years (when using non-volatile semiconductor memory)
Tightening torque	Housing: 1 N m, Terminal: 0.9 N m
Galvanic insulation	1 kVAC~ (Input/Output)
Ambient temperature	-40 to 85 °C, Storage: -40 to 85 °C (rated at no freezing or condensation)
Ambient humidity	5 to 95 %RH, Storage: 5 to 95 %RH (rated at no freezing or condensation)
Protection structure	Housing: IP40 (IEC standard), Terminal: IP00 (IEC standard)
Material	Case: PC
Certification	CE

Environmental Influence

- This is based on the state of 24 VDC≒ power supply, 250 Ω load, 25 °C ambient temperature and 10 min warming up time.

CJC error	± 1 °C
Temperature influence	Input error (TC), Input error (RTD), Output error
Input error (TC)	0.015 % F.S. / 1 °C (1.8 °F)
Input error (RTD)	0.015 % F.S. / 1 °C (1.8 °F)
Output error	0.1 % F.S. / 10 °C (18 °F)
Power supply voltage fluctuations	0.002 % F.S. / V
Load fluctuations	0.002 % F.S. / 100 Ω

Input Specifications

- Input accuracy excluded range
Thermocouple: K (≤ -190 °C), T (≤ -200 °C), S, B, R (≤ 400 °C)

Input type		Input range (°C)	Input range (°F)	Min. span (°C)
Thermocouple	K (NiCr-Ni)	-270 to 1372	-454 to 2501.6	50
	J (Fe-CuNi)	-210 to 1200	-346 to 2192	
	E (NiCr-CuNi)	-270 to 1000	-454 to 1832	
	T (Cu-CuNi)	-270 to 400	-454 to 752	
	N (NiCrSi-NiSi)	-270 to 1300	-454 to 2372	500
	B (PtRh30-PtRh6)	0 to 1820	32 to 3308	
	R (PtRh13-Pt)	-50 to 1768	-58 to 3214.4	
	S (PtRh10-Pt)	-50 to 1768	-58 to 3214.4	
RTD	DPt100 Ω	-200 to 850	-328 to 1562	10
	DPt500 Ω	-200 to 250	-328 to 482	
	DPt1000 Ω	-200 to 250	-328 to 482	
	Ni100 Ω	-60 to 180	-76 to 356	
	Ni500 Ω	-60 to 180	-76 to 356	
	Ni1000 Ω	-60 to 150	-76 to 302	
	JPt100 Ω	-200 to 600	-328 to 1112	
Resistance transmitter	Resistance (Ω)	0 to 400 Ω	-	10 Ω
		0 to 2000 Ω		
Analog	Voltage	-10 - 75 mV	-	5 mV
		-100 - 100 mV		10 mV
		-100 - 500 mV		20 mV
		-100 - 2000 mV		